

**Incite PS-400 Series
Fire Alarm Power Supplies
Installation, Commissioning,
and Operations Manual**

Man-1128IN PS-400 (IN-K25000) Series
Issue 3.20 November 2017

Contents

1	General.....	3
1.1	Australian Part Number.....	3
1.1.1	Power Supply in an Enclosure.....	3
1.1.2	Power Supply without an Enclosure.....	3
2	Power Requirements.....	3
2.1	Input/Output Electrical Ratings.....	3
2.2	Fuse Ratings.....	4
2.3	Batteries.....	5
3	Installation.....	5
3.1	Environmental Considerations.....	5
3.2	Mounting.....	6
3.3	Connecting to the Mains Input.....	8
3.4	Connecting to the Outputs.....	9
3.4.1	Load Connections (Terminal Block).....	9
3.4.2	Load Connections (Ribbon Cable).....	9
3.4.3	Load connections (optional dual transmission path PCB fitted).....	10
3.4.4	Fault output contact connections.....	11
3.4.5	Battery Connections.....	11
3.4.6	Disabling battery disconnected indication (IN-K25800 only).....	14
3.4.7	Disabling the battery impedance test (IN-K25800 only).....	14
4	Indicators.....	15
5	Commissioning.....	16
6	Maintenance.....	16
7	Standby batteries.....	17
8	Power Supply Unit Dimensional Drawings.....	18
9	Temperature sensor mounting.....	21
10	Cabling.....	21
10.1	Mains.....	21
10.2	Extra Low voltage wiring.....	21
11	Mains Voltage Selection (IN-K25250 and IN-K25400 ONLY).....	22
12	Revision Details.....	23

1 General

The IN-K25000 series are combined power supply and battery chargers designed to be used for fire alarm control and indicating equipment complying with AS7240-2 and AS7240-4.

To satisfy the requirement of clause 6.4 of AS7240-4, for fire alarm Power Supply Equipment mounted in a separate enclosure to the Control and Indicating Equipment, a separate interface (RPSM2) needs to be fitted inside the PSE enclosure which provides two transmission paths between the PSE and the CIE to enable one transmission path to continue to operate in the event of failure of the other.

When this board is fitted, a 'D' is added to the prefix to become 'KD'. The D denoting that the dual output board is fitted.

1.1 Australian Part Number

For the Australian part number reference



1.1.1 Power Supply in an Enclosure

PS407-xx	3.5 Amp is referred to in this manual as	IN-K25250
PS406-xx	5.25 Amp is referred to in this manual as	IN-K25400
PS408-xx	10.25 Amp is referred to in this manual as	IN-K25800

(where -xx indicates the variant of enclosure which determines the maximum battery size)

1.1.2 Power Supply without an Enclosure

PS406	5.25 Amp is referred to in this manual as	IN-K25400
PS408	10.25 Amp is referred to in this manual as	IN-K25800

2 Power Requirements

The IN-K25000 series require a mains power supply of 230V AC.

The maximum input current is 3A for IN-K25250 and IN-K25400 and 5A for IN-K25800.

Mains frequency should be 50Hz or 60Hz.

2.1 Input/Output Electrical Ratings

Input – IN-K25250 and IN-K25400: 110V AC or 230V AC (selected by link inside the power supply unit)

– IN-K25800: 115VAC – 230VAC

Load output - 19V DC minimum, 30V DC maximum

Maximum output current –

IN-K25800 models 8 Amps + 2.25A for battery charging.

IN-K25400 models 4 Amps + 1.25A for battery charging.

IN-K25250 models 2.5Amps + 1.0 A for battery charging.

Maximum ripple - 1 Volt.

Imax a – Rated maximum output current which can be supplied continuously

IN-K25800 models: 8A

IN-K25400 models: 4A

IN-K25250 models: 2.5A

I_{max b} – Rated maximum output current which can be supplied while battery charging is not required

IN-K25800 models: 10.25A

IN-K25400 models: 5.25A

IN-K25250 models: 3.5A

I_{min} - Minimum output current for correct operation = 10mA

R_{i max} – Maximum series resistance in battery charging circuit before a fault is indicated:

IN-K25800 models: 0.4 Ohms

IN-K25400 models: 1.0 Ohms

IN-K25250 models: 1.0 Ohms

Battery charging output:

IN-K25800 models: 26.4 V DC (at 40°C) to 28.9 V DC (at -5°C) 2.25 Amps max.

IN-K25400 models: 26.4 V DC (at 40°C) to 28.9 V DC (at -5°C) 1.25 Amps Max.

IN-K25250 models: 26.4 V DC (at 40°C) to 28.9 V DC (at -5°C) 1.0 Amps Max.

Fault signals - Switched negative open collector (with respect to load positive) current limited 100mA max.

Mains fail

Battery disconnected (Low battery shutoff voltage - 19 V (± 1 volt))

Battery voltage low/Battery connection high impedance.

Low battery voltage: 21V ± 1 volt

Earth fault

Charger fault (high output to battery)

Fail safe (any one of the above)

2.2 Fuse Ratings

Input fuse: IN-K25250 / IN-K25400 F3A 250V TD 20mm.

IN-K25800 F5A 250V TD 20mm

(Replace only with a fuses of the same type).

Load fuse: Self-resetting Polyfuse

IN-K25250: 3 Amp

IN-K25400: 5 Amp.

IN-K25800: 10 Amp

RPSM2 fuses: FF very fast acting. (Replace only with fuses of the same type).

IN-K25250: 6.3 Amp

IN-K25400: 6.3 Amp.

IN-K25800: 12 Amp

2.3 Batteries

Maximum battery capacity is dependent on the power supply and the cabinet in which it is installed.

Rechargeable, sealed lead acid Yuasa NP or Powersonic or equivalent. Maximum capacity is 33Ah for IN-K25400-M3D, 22Ah for IN-K25400-M3, 12AH for IN-K25250-M2D, and 7AH for IN-K25250-M2 models dependant on battery footprint.

Other battery manufacturers are available on request.

Maximum current consumption from battery:

IN-K25800: 11 Amps.

IN-K25400: 7 Amps.

IN-K25250: 5.5 Amps.

Quiescent current in mains failure mode: 70 milliamps.

IN-K25800: 50 milliamps.

IN-K25400: 70 milliamps.

IN-K25250: 70 milliamps.

3 Installation

This product should be installed, commissioned and maintained by trained service personnel in accordance with the following:

- (i) Regulations for electrical equipment in buildings specific to the country of use
- (ii) Codes of practice
- (iii) Statutory requirements
- (iv) Any instructions specifically advised by the manufacturer

3.1 Environmental Considerations

The IN-K25000 series power supplies are mounted in steel enclosures with an ingress protection rating of IP30. The operating temperature range should not exceed -5°C to $+40^{\circ}\text{C}$ ($\pm 2^{\circ}$). Humidity levels should not exceed 95% (non-condensing).

3.2 Mounting

The unit should be mounted on a dry, flat surface and in a level position such that the enclosure is not distorted.

Screws or bolts of a minimum of 5mm diameter and suitable wall fixings must be used to mount the enclosure in all three or four mounting positions, and should be positioned in an accessible place as agreed with the end user.

The unit should not be mounted in another enclosure or near sources of excessive heat. Cables should be connected using suitable, metal cable glands fitted to the knockouts provided. If additional cable entry points are required, all swarf and debris caused by drilling of additional cable entries must be cleared before power is applied to the unit.

The equipment is of Class1 construction so must be permanently and reliably connected to the fixed earth of the installation.

The primary earth of the end use application must be permanently marked with the protective earth symbol (IEC415 No. 5017). A suitable primary disconnecting device must be provided in the end use application.

Battery and load connections must be considered for connection to SELV (safety extra low voltage) circuits only.

The maximum leakage current of the completed and installed equipment must not exceed 3.5mA.

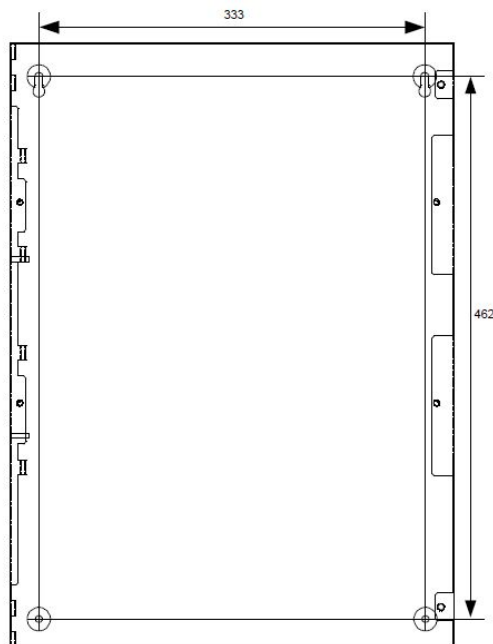

IN-K25000-M3 Fixing Centres

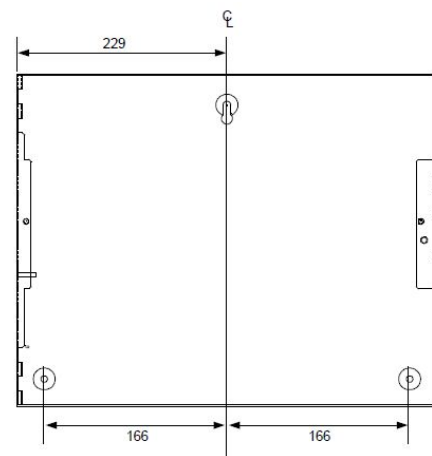

IN-K25000-M2 Fixing Centres

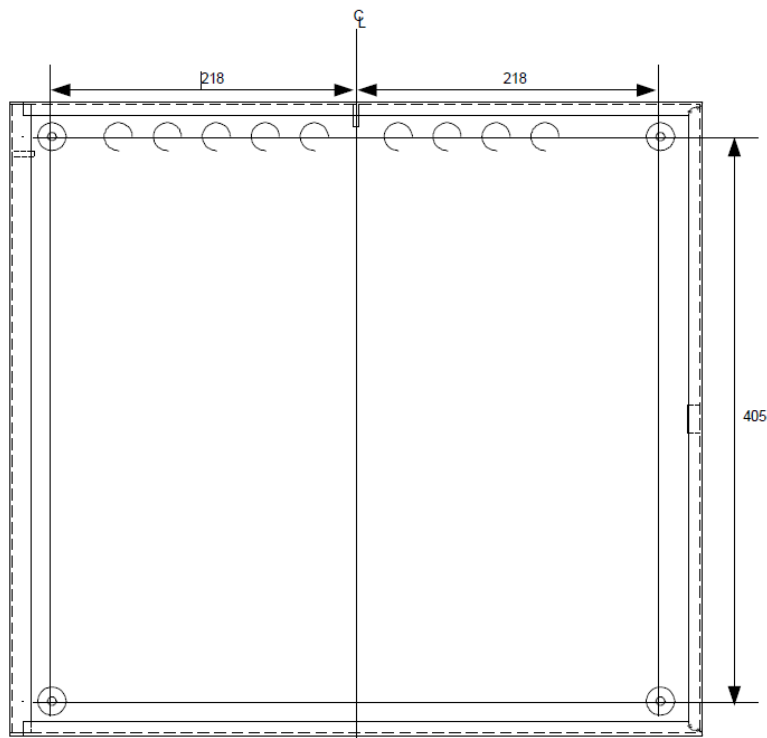
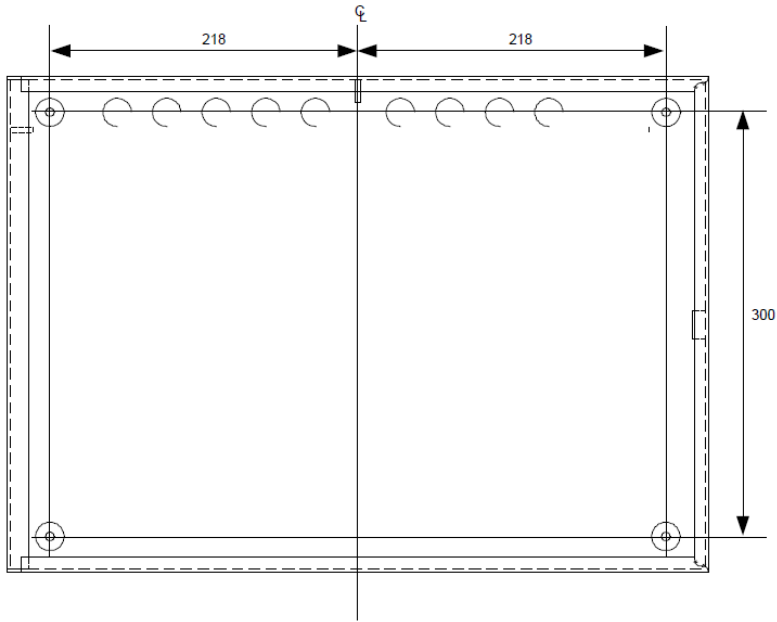

3.3 Connecting to the Mains Input

Do not connect a mains supply unless the supply voltage matches that shown on the rating plate.

A minimum cable size of 1.0mm² must be used. Maximum cable size is 4.0mm². The mains cable should be rated at 250V and fused via a 5A anti-surge fuse.

Fit the mains cable via a suitable cable gland via a knockout close to the power supply unit. Connect the Neutral of the mains power supply to the terminal marked 'N', connect the Live of the mains power supply to the terminal marked 'L' and connect the earth to the terminal marked 'E'.

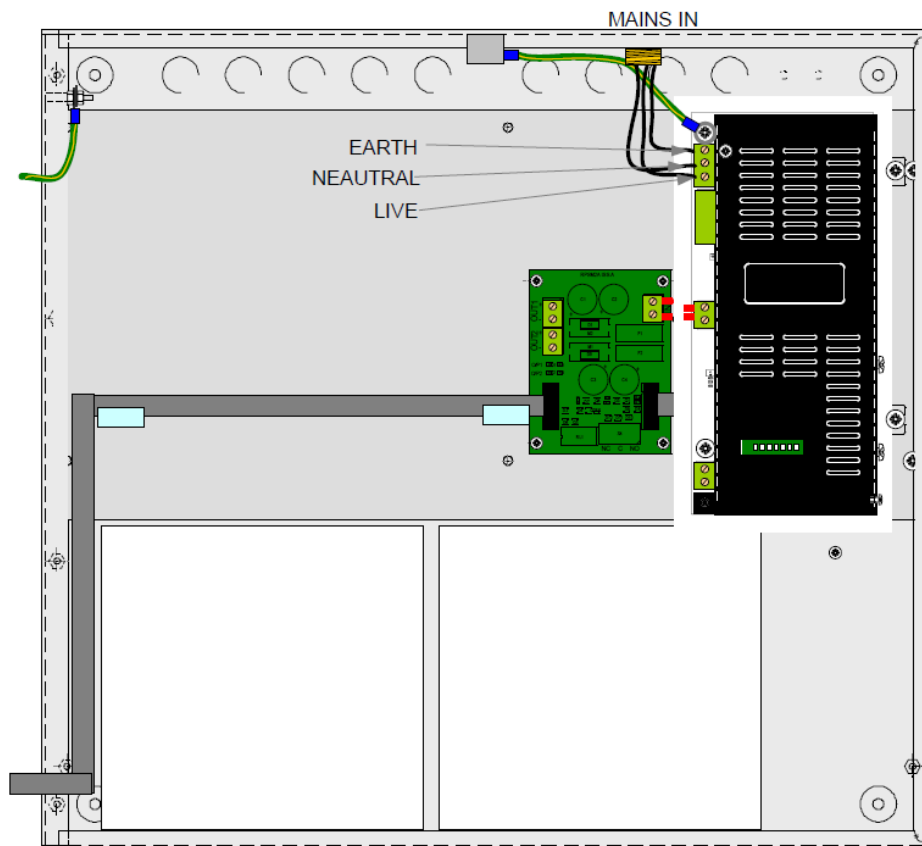

The mains wiring should be as short as is practical with no excess lengths or larger loops and be separated from all extra low voltage wiring such as 24V supply wiring and battery leads. Ensure that all wires are fitted into the terminals without any exposed lengths or strands which may give rise to exposure to electrical shock.

This equipment is designed to be operated from 230V 50Hz mains supplies and is of class 1 construction. As such it **must** be connected to a protective earthing conductor in the fixed wiring of the installation and a readily accessible double pole disconnect device which disconnects live and neutral simultaneously shall be incorporated in the fixed wiring as close to the unit as is practical.

Ensure that all screws in the earth terminal block (including those that are not used) are tightened during installation.

3.4 Connecting to the Outputs

3.4.1 Load Connections (Terminal Block)

On IN-K25000 units, two terminals are provided for connection of the load. +24V DC and DC RETURN.

The load should be connected using wire rated for at least 10 Amps continuous.

Care must be taken to connect the polarity of the load the correct way around, + on the PSU to + on the load and - on the PSU to - on the load.

Note: Maximum cable size is 2.5mm

A Wurth 742 711 31, clip on ferrite must be fitted to the load cable before it exits the enclosure. This is supplied.

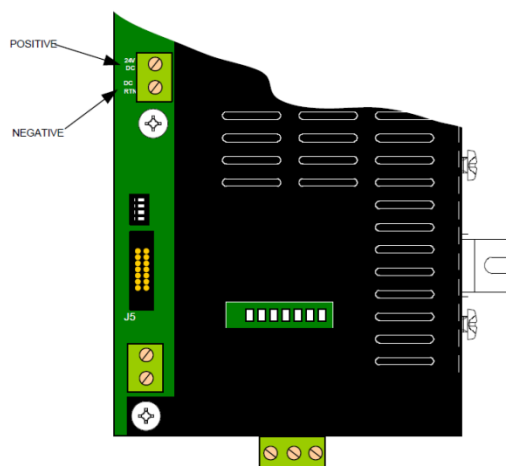

3.4.2 Load Connections (Ribbon Cable)

An alternative method of connecting to the power supply is via a 14-way ribbon cable.

The ribbon cable must not leave the enclosure

A standard latching ribbon cable header is provided on the board, which may be used to connect to the load, and fault signals. (See below.)

Pin 1 = Negative

Pin 2 = Negative

Pin 3 = Negative

Pin 3 = Negative

Pin 5 = Positive 24V

Pin 6 = Positive 24V

Pin 7 = Positive 24V

Pin 8 = Positive 24V

Pin 9 = Battery disconnected (switched -ve 100 milliamps max)

Pin 10 = Mains failed (switched -ve 100 milliamps max)

Pin 11 = Battery low/High impedance (switched -ve 100 milliamps max)

Pin 12 = Earth fault (switched -ve 100 milliamps max)

Pin 13 = Charger fault (switched -ve 100 milliamps max)

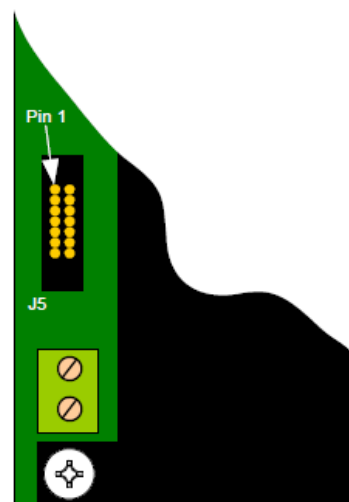

The ribbon cable should not be used alone but always in conjunction with connections to the load terminals 24V DC and DC RTN as described in 3.4.1 above.

3.4.3 Load connections (optional dual transmission path PCB fitted)

When the power supply unit is being used to supply power to fire alarm control and indicating equipment, to comply with the requirements of AS7240-4, there must be two transmission paths from the power supply to the control panel in order that a short or open circuit in one transmission path will enable the control panel to be supplied with power from the other.

This is facilitated by the RPSM2 PCB which is mounted in the enclosure as standard on IN-KD25000 models. The RPSM2 PCB has a common fault relay which signals any of the faults associated with the power supply including failure of one of these transmission paths.

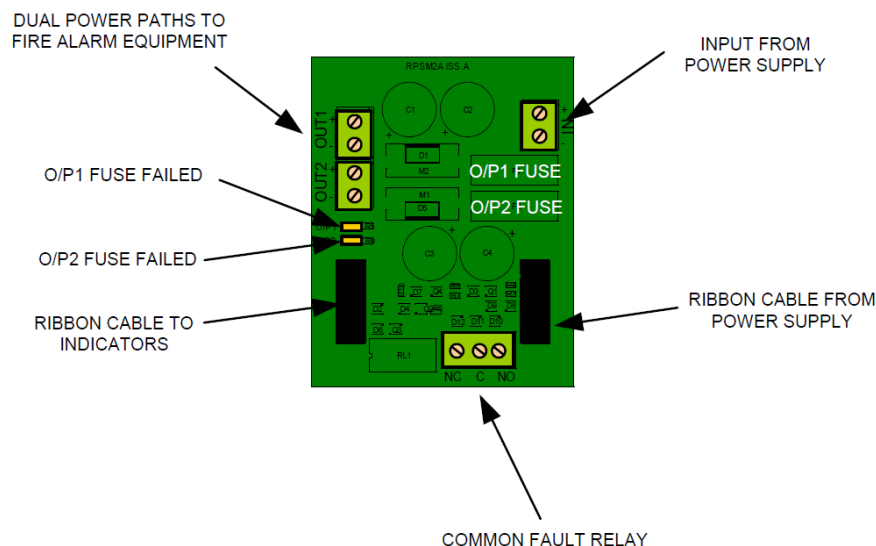

When connecting power to fire alarm control and indicating equipment, the connections OUT1 + and OUT1- should be connected to one power input of the control and indicating equipment and the connections OUT2 + and OUT2- should be connected to the other power input of the fire alarm control and indicating equipment.

Only fire alarm control and indicating equipment with two separated 24V DC inputs is compatible with these power supply units.

Care must be taken to connect the polarity the correctly, + on the RPSM2 PCB to + on the control panel and - on the RPSM2 PCB to - on the control panel.

The total load over the two outputs should not exceed 10.25 Amps on IN-K25800 models, 5 Amps on IN-K25400 models and 3.5 Amps on IN-K25250 models.

Failure to connect the polarity correctly could result in damage to the control panel, the power supply or both.

The common fault relay is normally energised and will operate to signal any fault associated with the power supply or total power failure.

The fuses on the RPSM2 PCB must be replaced only with the correct type as described in section 2.2 of this manual.

Note: A Wurth 742 711 31, clip on ferrite must be fitted to each of the load cables before they exit the enclosure. These are supplied.

3.4.4 Fault output contact connections

A volt free contact rated at 30V DC and 1 Amp is available for connection to other systems.

This contact will operate upon any of the fault conditions listed in section 0.

The contact positions shown here are with mains and battery connected and with no fault conditions on the power supply.

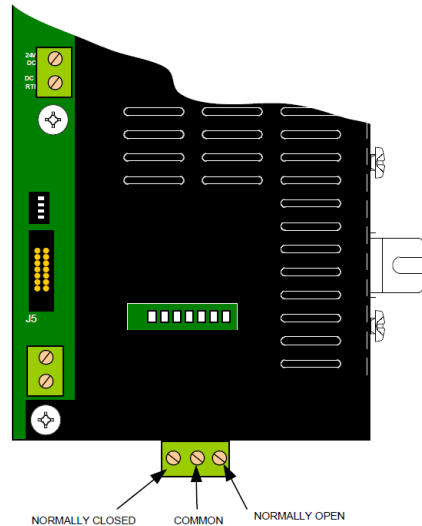

3.4.5 Battery Connections

Batteries of even very small capacity are capable of delivering very high currents which can cause fire or injury. Battery connections must therefore be made using **extreme caution**.

As supplied, power supplies have battery leads already wired to the battery terminals on the circuit board. These leads are coloured red for + and black for - and are fitted with standard ¼ inch push on, spade connectors suitable for batteries of up to 12Ah capacity.

Larger capacity batteries have screw on terminals and the standard battery leads will need to be replaced with the ones supplied in the accessory pack. Take care that the red and black wires are connected to the correct terminals when replacing battery leads, a wrong connection can be dangerous and can cause damage.

As this is a 24-Volt system, there will be two 12 volt batteries which need to be connected in series. This is done using the jumper link provided.

To optimise the service life of the batteries, the battery charger output voltage varies with temperature. To enable optimum temperature compensation, the flying lead temperature sensor should be attached to one of the batteries as shown in the diagram in section 0 of this manual.

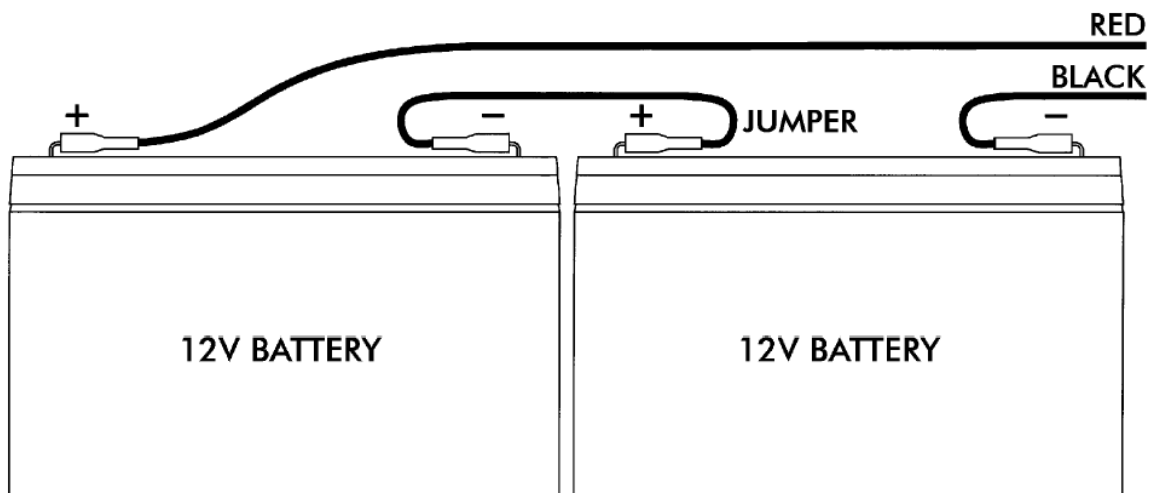

In order to correctly charge the batteries, the power supply must be matched to the type of batteries that are connected to it.

This is done by setting the DIP switch located next to the ribbon cable connector J5. Switch 1 is to choose the battery manufacturer (Yuasa or Powersonic). Switches 2, 3 and 4 must be left in the OFF position.

3.5 IN-K25250 and IN-K25400 DIP Switch Settings

3.5.1 Battery Type Selection

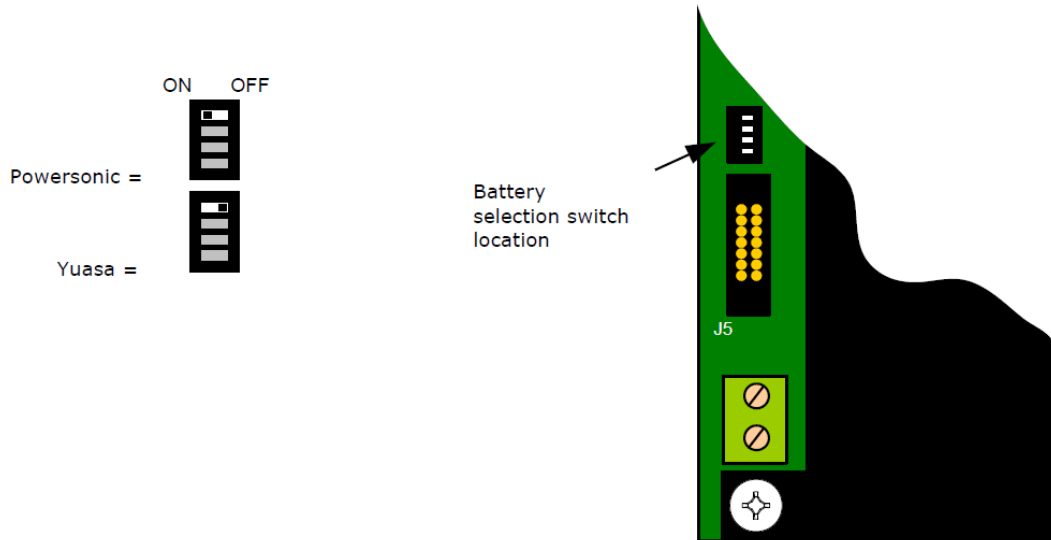

3.5.2 Disabling battery disconnected indication (manufactured after Feb 2016)

When the power supply is to be used without standby batteries, the battery disconnected warning indication and operation of the common fault relay may be disabled by setting position 1 on the DIP switch to the ON position as show in the diagram below.

NOTE: In order to comply with the requirements of EN54-4 this switch setting must not be used when the power supply is being used to power fire alarm detection and control equipment.

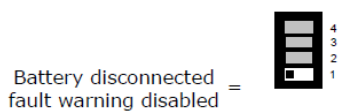

3.5.3 Disabling earth fault indication

It is possible to disable the reporting of an earth connection to the 24V output or battery, by setting DIP switch 3 to the ON position as shown below. This is not recommended during normal operation and could render the system unsafe if two earth faults occur which short the 24V supply.

NOTE: In order to comply with the requirements of EN54-4 this switch setting must not be used when the power supply is being used to power fire alarm detection and control equipment.

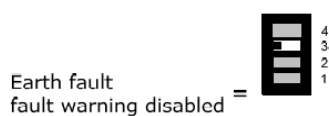

3.6 IN-K25800 DIP Switch Settings – Pre Firmware version v01.01.00 (August, 2016)

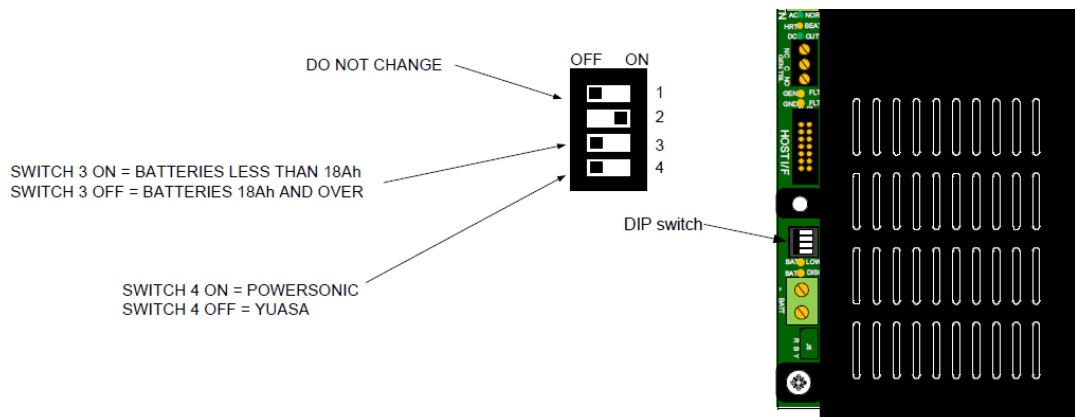

3.7 IN-K25800 New option Firmware version v01.01.00 and later (August, 2016)

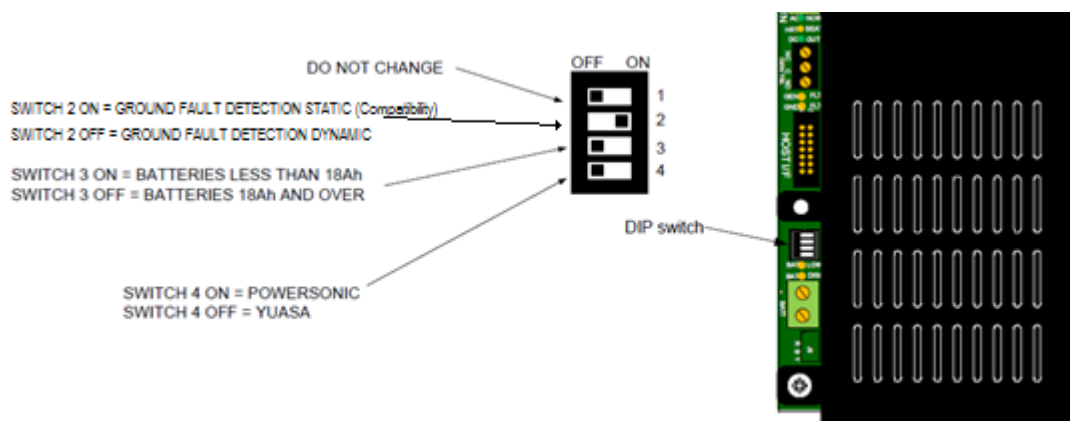

SW1: MUST REMAIN OFF

SW2: Ground Fault Detection Scheme.

On *Static / Compatibility* EARTH is pulled to a static voltage potential midway between 24V and RTN ($\frac{1}{2}$ of 24V-OUT).

Off *Dynamic / Normal* EARTH is pulled to a dynamic, cycling voltage ranging from roughly $\frac{1}{4}$ to $\frac{3}{4}$ of 24V-OUT.

3.7.1 Disabling battery disconnected indication (IN-K25800 only)

When the power supply is to be used without standby batteries, the battery disconnected warning indication and operation of the common fault relay may be disabled by setting switch 1 on the DIP switch to the ON position, switch 3 to the ON position and switch 4 to the OFF position.

3.7.2 Disabling the battery impedance test (IN-K25800 only)

It is possible to disable the battery impedance test and fault reporting by setting switch 1 to the ON position, switch 3 to the OFF position.

3.7.3 Disabling earth fault indication (IN-K25800 only - August 2016 onwards)

In applications where the output cannot be isolated from earth, the earth fault warning indication and subsequent operation of the common fault relay may be disabled by setting switch 1 to the ON position, switch 2 to the OFF position, switch 3 to the ON position and switch 4 to the ON position.

NOTE: In order to comply with the requirements of AS7240-4: Switch 1 must be OFF and Switch 2 must be ON.

No other setting must be used when the power supply is being used to power fire alarm detection and control equipment.

4 Indicators

The diagnostic indicators visible through the case of the power supply indicate the status of the unit as follows:

DC OUT ON – The 24V DC output is supplying power to the load.

HEARTBEAT (flashing slowly) – The processor is functioning normally.

BATTERY DISCONNECTED – The battery is disconnected or the charging circuit has reached a higher impedance than it should.

BATTERY LOW – The battery voltage is below 21 Volts.

CHARGER FAULT – The battery charge voltage is too high.

EARTH FAULT – The 24V DC supply is connected to earth.

AC NORM – Mains power is connected.

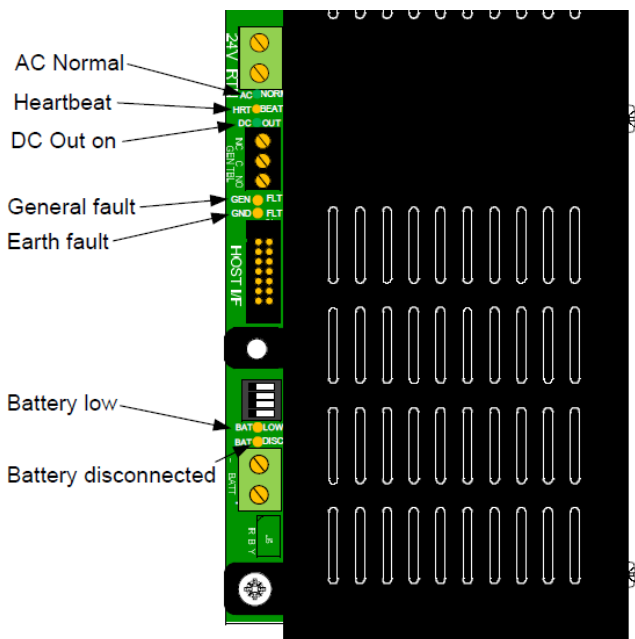
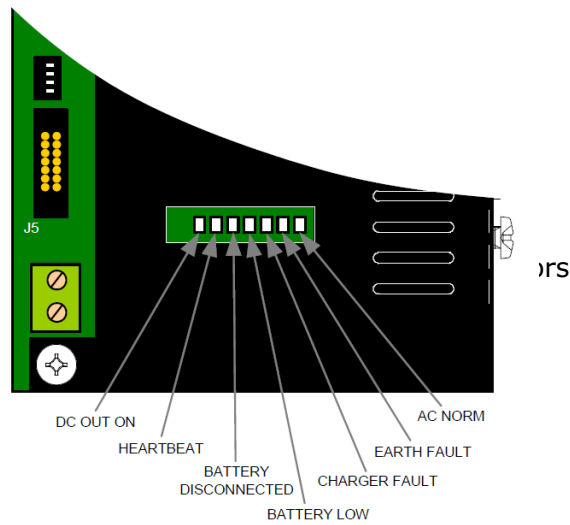

5 Commissioning

Once all connections have been made and checked for safety, switch on the mains power. The load should now be supplied with power and the batteries should be taking a charge. Check the load is being supplied at about 24 Volts with a volt meter.

Check that the AC NORMAL LED is on.

Check that the HEARTBEAT LED is flashing slowly.

Check that the load is being supplied by observing the power on lamp on the load (control and indicating equipment).

Remove the mains power and ensure that the batteries continue to supply power to the load.

With the mains removed, the AC NORMAL indicator should switch off within 30 seconds.

Switch the mains back on and disconnect the battery. The load should continue to operate and the BATTERY DISCON. LED should light after a short delay.

Connect the load+ terminal to earth using a piece of wire. Within 30 seconds, the GROUND FAULT LED should light.

Disconnect the load+ from earth and wait for the fault to clear.

Connect the load- to earth. Within 30 seconds, the GROUND FAULT LED should light.

Disconnect the load- from earth and wait for the fault to clear.

This completes the basic commissioning checks.

6 Maintenance

The power supply requires no specific maintenance; however, sealed lead acid batteries have a limited lifespan and should be checked periodically in accordance with the manufacturer's recommendations and replaced as recommended below.

The only replaceable parts are the mains fuses and fuses on the dual power output board RPSM2 on IN-KD25000 models.

Should a fuse fail, the fuse **must only be replaced with fuses of the same type as originally fitted**. Spare fuses are supplied in the accessory pack. Care must be taken to select the correct one when replacing fuses.

These are as follows:

Mains Input fuse - F3A (IN-KD25250/400) or F5A (IN-KD25800) 250V TD 20mm. (Replace only with fuses of the same type).

IN-KD25000 series RPSM2 fuses- FF very fast acting 3.3A (IN-KD25250/400) or 12A (IN-KD25800). (Replace only with fuses of the same type).

7 Standby batteries

Sealed lead acid batteries have an expected life of 3 to 5 years when operated at an ambient temperature of 20°C.

Batteries operating in temperatures higher than 20°C will have a significantly reduced life of approximately 50% for every 10°C above 20°C.

This must be considered when determining the battery maintenance schedule and batteries consistently operating in higher ambient temperatures should be replaced more frequently.

Batteries with a manufacturing date older than 6 months are not recommended for use with this equipment.

Sealed lead acid batteries can liberate hydrogen during normal use. The IN-K25000 series of power supplies have adequate ventilation to allow this hydrogen to disperse normally and safely therefore additional sealing or mounting inside a sealed enclosure is prohibited.

Batteries contain hazardous substances and must be returned to the supplier or manufacturer for disposal.

Refer to battery manufacturers recommendations for further information.

Compatible batteries:

Model	Yuasa	Powersonic
IN-K25250-M2	NP4-12, NP7-12	PS-1242, PS-1270, PS-12120
IN-K25250-M2D	NP4-12, NP7-12, NP12-12	PS-1242, PS-1270, PS-12120
IN-K25400-M3	NP4-12, NP7-12, NP12-12, NP18-12	PS-1242, PS-1270, PS-12120, PS-12170
IN-K25400-M3D	NP4-12, NP7-12, NP12-12, NP18-12, NP24-12, RA12-33	PS-1242, PS-1270, PS-12120, PS-12170, PS-12260, PS-12330
IN-K25800-03	NP4-12, NP7-12, NP12-12, NP-17-12, NP18-12B	PS-1242, PS-1270, PS-12120, PS-12170
IN-K25800-15	NP4-12, NP7-12, NP12-12, NP-17-12, NP-24-12, NP18-12B, NP38-12I	PS-1242, PS-1270, PS-12120, PS-12170, PS-12260, PS-12450
IN-K25800-M3	NP4-12, NP7-12, NP12-12, NP-17-12, NP18-12B*	PS-1242, PS-1270, PS-12120, PS-12170*
IN-K25800-D3	NP4-12, NP7-12, NP12-12, NP-17-12, NP18-12B, NP-24-12, NP-38-12, NP38-12I	PS-1242, PS-1270, PS-12120, PS-12170, PS-12260, PS-12450

NOTE: When selecting a battery, first check dimensions to ensure that it will fit within the desired cabinet size.

8 Power Supply Unit Dimensional Drawings

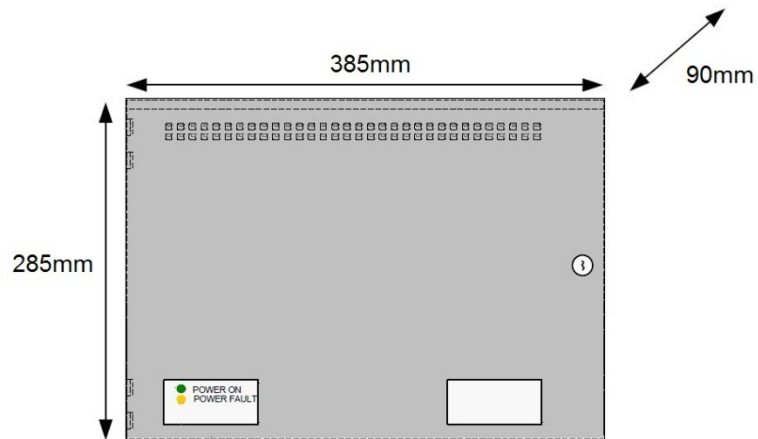

IN-K25250-M2 Cabinet

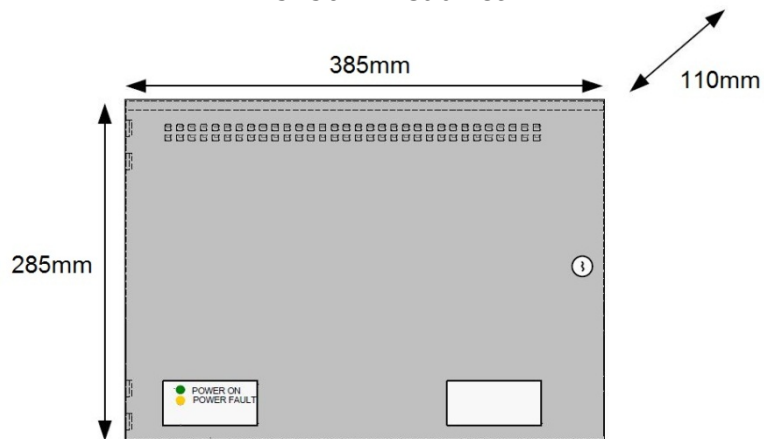

IN-K25250-M2D Cabinet

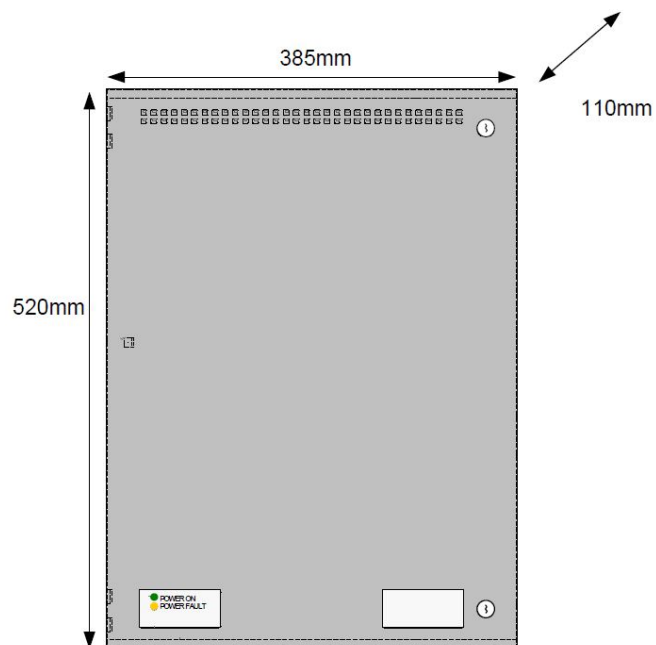

IN-K25400-M3 and
IN-K25800-M3 Cabinet

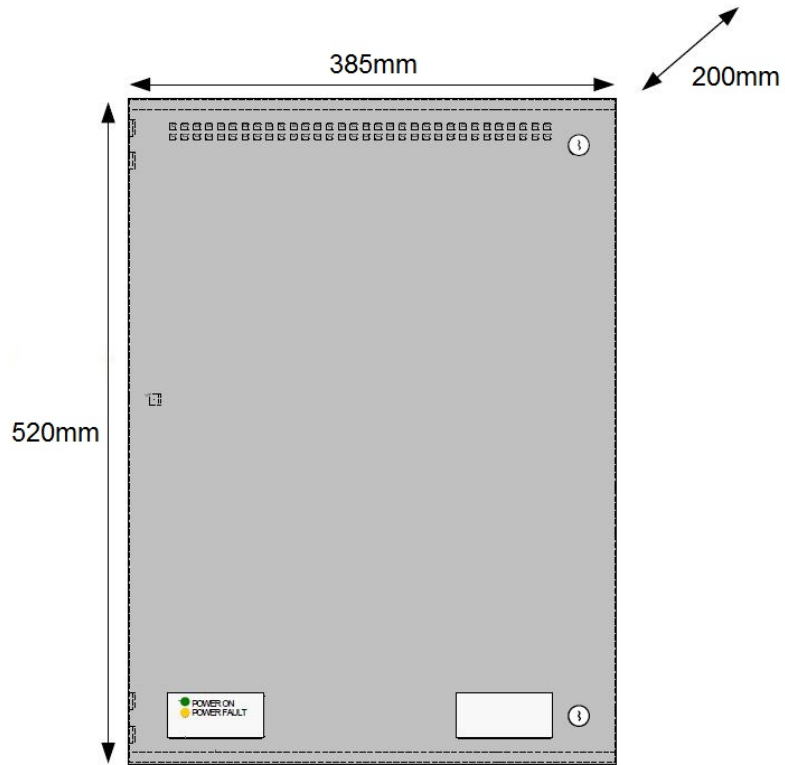

IN-K25400-M3D and
IN-K25800-M3D Cabinet



IN-K25800-03 Cabinet



IN-K25800-15 Cabinet

9 Temperature sensor mounting

To achieve correct battery charging temperature compensation (essential for correct maintenance of batteries) the flying lead thermistor must be affixed to one of the batteries using Scotch 27 Glass Cloth Electrical Tape or equivalent. A suitable piece of this tape is supplied holding the temperature sensor to the power supply chassis.

Remove tape holding temperature sensor to power supply chassis and use it to fit the temperature sensor to one of the batteries roughly in the position shown below

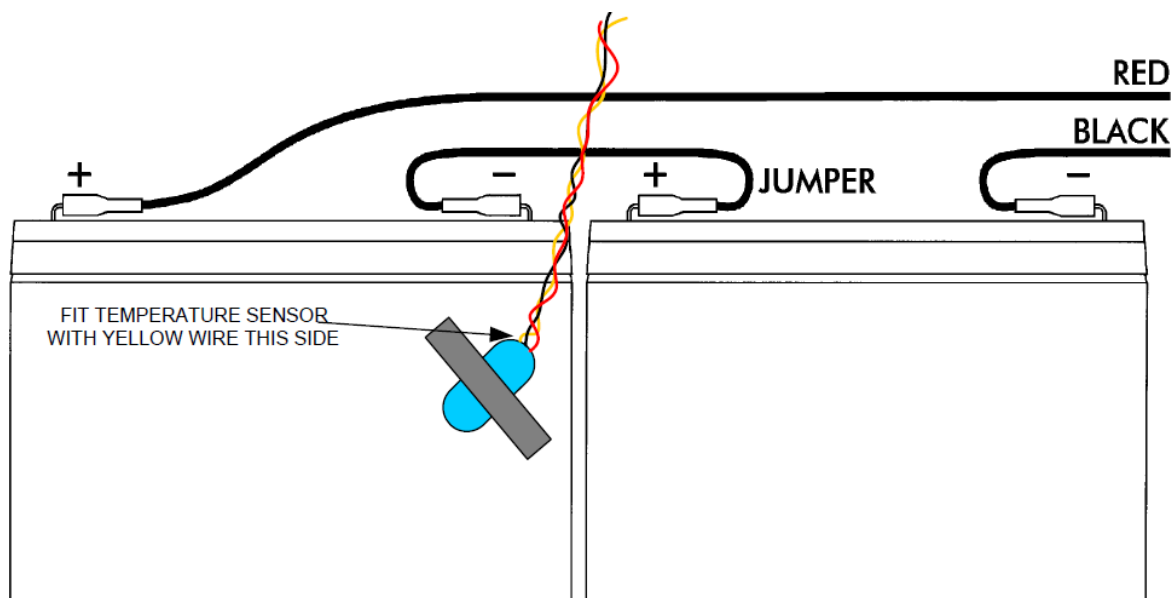

10 Cabling

10.1 Mains

The Mains cable should be a minimum cable size of 0.75mm² and rated at 250V. A suitable primary disconnecting device must be provided in the end use application. Maximum cable size is limited to 4mm².

Keep all mains wiring separate from the Extra Low Voltage (ELV) battery cables and power supply output cables

10.2 Extra Low voltage wiring

Cable for low voltage wiring should be a minimum size of 1.0mm² and rated for at least 30V DC. Keep all Extra Low voltage wiring separate from mains wiring

All cable entries to the enclosure must be via suitable cable gland.

11 Mains Voltage Selection (IN-K25250 and IN-K25400 ONLY)

The IN-K25250 and IN-K25400 series power supplies will be supplied as 240V input voltage selected as standard, but may be optionally supplied as 110V if requested when the power supply was ordered.

The selected voltage of the power supply is clearly shown on the power supply cover.

In the unlikely event that the power supply input voltage needs to be changed, this may be performed by the addition/ removal of a link on the power supply circuit board, using the following procedure.

WARNING:

High voltages exist within the power supply unit. Ensure that the mains power is switched off and fully isolated before working on the power supply.

- 1) Ensure that the mains power feed is disconnected and isolated from the power supply unit.
- 2) Disconnect and insulate the mains input cables from the power supply
- 3) Disconnect the battery leads from the standby batteries (if connected)
- 4) Carefully remove the 14 way ribbon cable connected to J5
- 5) Remove the cables from the 24V DC load terminals
- 6) Loosen the two M4 screws located on the fixing flanges on the right hand side of the power supply unit
- 7) Carefully remove the two M4 screws on the left side of the power supply unit, ensuring any washers & ring crimps are kept safe. These screws are located in the top left corner of the power supply and between the battery lead terminals and ribbon connector plug.
- 8) It should be possible to remove the power supply unit from the enclosure.
- 9) The cover of the power supply can now be removed by removing three small Posidriv screws / washers. Two of these are located on the right side of the power supply, the other in the top left corner of the power supply cover. A fourth screw located in the lower left of the power supply will also need to be removed before the cover can be carefully lifted away.
- 10) With the cover removed it is possible to see the circuit board with the mains input voltage selection link position

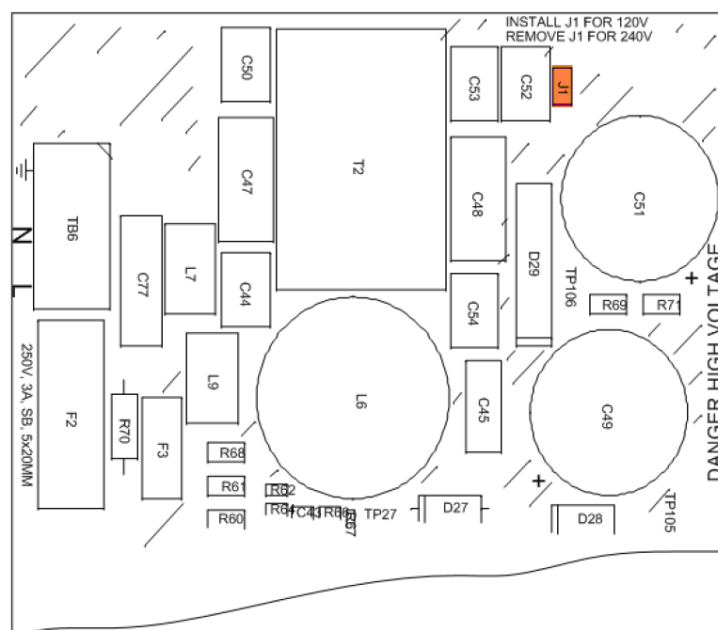

- 11) Link J1 should be removed for 240V operation, and fitted for 120V operation. Take care to ensure that the correct selection for the mains input voltage is made, as damage may occur to the power supply if the wrong mains voltage is applied.
- 12) Re-fit the power supply cover ensuring all four screws and washers are used.
- 13) Replace the power supply in the panel enclosure, ensuring all washers and earth bonding straps are correctly installed
- 14) Replace the ribbon cable, load cable and mains / battery connections
- 15) Modify the input voltage selection on the power supply cover to show the correct input voltage for the power supply

Note: When the power supply is removed from the panel enclosure, it is possible to view the link location on the circuit board through an aperture in the outer cover at the top of the power supply. Long nosed pliers may be used to carefully remove or place the link in the power supply board, rather than removing and replacing the power supply cover.

Damage due to incorrect voltage selection will void the Warranty.

12 Revision Details

Revision Number	Reason	Date of issue
V3.0	Initial Release	
V3.1	Updated Australian part numbers, updated PS408 10Amp PSU DIP setting after F/W version 01.01.00 or later and updated Incite contact details	28/04/2016
V3.2	Updated PS406, PS407 Dip Switch Settings after Feb 2016	17/11/2017

Sydney

Block Y, Unit 1, 391 Park Road, REGENTS PARK NSW 2143
Mail: PO Box 508 GYMEA NSW 2227
Phone: 1300 INCITE (1300 462 483) | 02 9644 7144
Fax: 02 9644 7255
Email: sales@incitefire.com.au
Technical support: support@incitefire.com.au

Melbourne

Address: Unit 120, 45 Gilby Road, MT WAVERLEY VIC 3149
Phone: 03 9544 2211
Fax: 03 9544 2212
Email: salesvic@incitefire.com.au

Brisbane

Address: 25 Jeays Street, BOWEN HILLS QLD 4006
Phone: 07 3252 5366
Fax: 07 3252 4099
Email: salesqld@incitefire.com.au

Perth

Address: Unit 2, 48 Irvine Drive, MALAGA WA 6090
Phone: 08 9349 2972
Email: saleswa@incitefire.com.au